

Strand pelletizer

ips-SG / 2



- Cutting and draw-in devices with bearings on both sides
- Draw-in and cutting width 120 mm, 220 mm, 320 mm or 420 mm
- Sound insulation as standard
- Optimum accessibility to the cutting area for cleaning and maintenance
- Simple operation
- Compact, robust design
- Small footprint
- No electrical components on the cutting head
- Easy access to the pneumatic control system

Option: Automatic cutting gap adjustment (patented)

Option: Draw-in speeds up to 140 m/min

Option: Interface for integration into external control systems

Option: Cutting area cooling

Option: Separate drive of upper feed rollers, which means steel feed rollers can also be used

Option: Online pellet length adjustment

Option: Can be operated from the left or right

Option: Sub-frame and/or pellet outlet can be adapted to suit customer's requirements

Design details

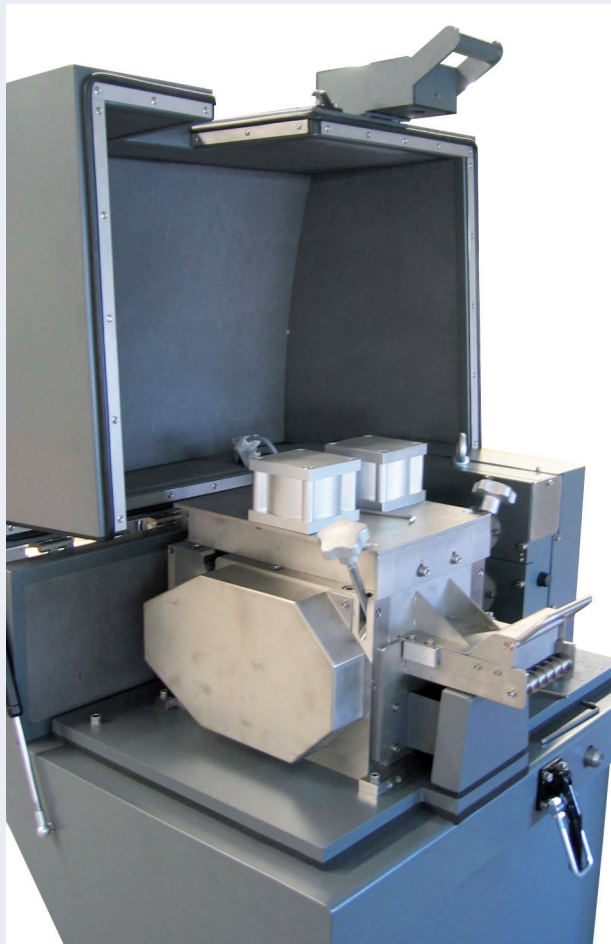

Optimum, safe accessibility to the cutting area, no electrical components on the cutting head housing

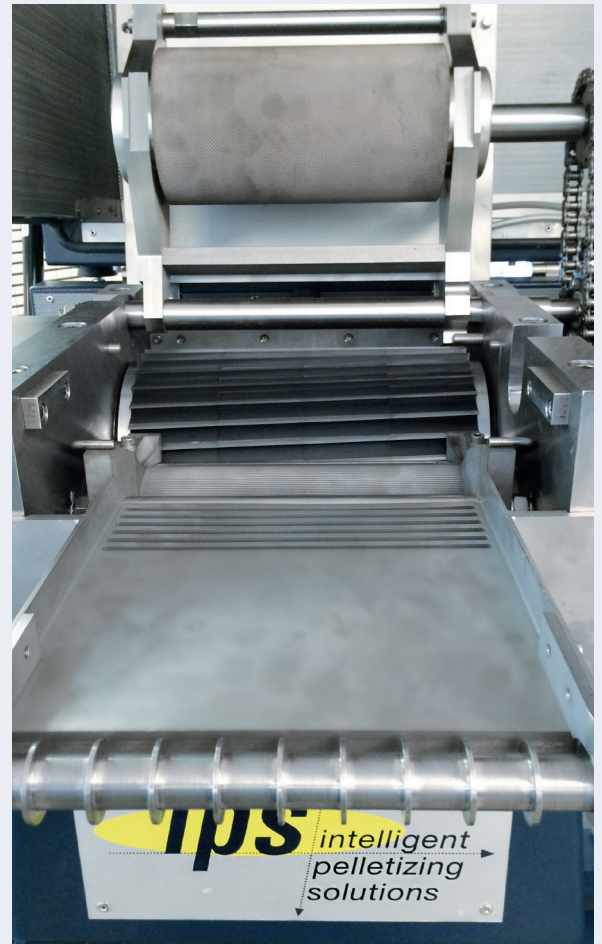

Strand infeed area – designed for ease of cleaning

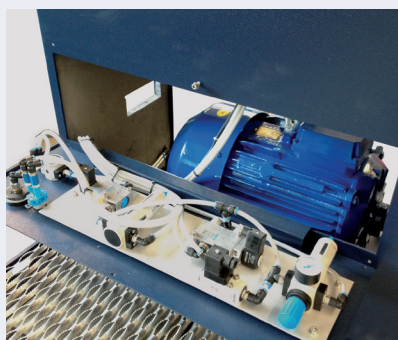

Easy access to the pneumatic control system



All sizes have two pneumatic cylinders on the upper feed roller for optimum feed action



Robust, clear operating and display elements



Option:
Online pellet
length adjustment



Option:
Driven upper
feed roller



Option:
Operation from
left or right

Options and accessories

ips systems are available with a range of options and accessories. We will be happy to advise you on the systems we offer, and the additions that will be best for you.



Automatic cutting gap adjustment



Cutting area cooling

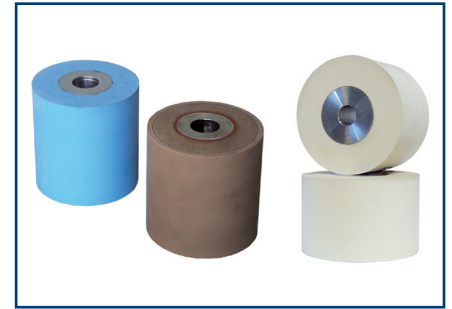

Various coatings for the upper feed roller



Strand feed from strand cooling trough to strand pelletizer

Other ips system components are available (strand die head, strand cooling trough, strand dewatering system, strand feed guide, classifier)

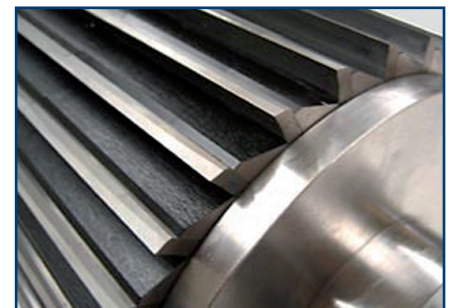

Cutting tools can be optimally adjusted to your requirements; cutting rotors of hardened chromium steel, of sintered PM steel or with clamped or soldered HM blades



Online pellet length adjustment



Sub-frame can be adjusted to suit the customer's requirements

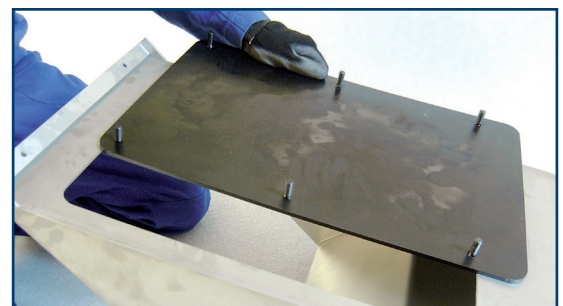

Pellet outlet with replaceable wear protection plate



Option:
Interface for data exchange



Pneumatic pressure on the upper feed roller



Option:
Automatic cutting gap adjustment

Technical data

Size	ips-SG 120 / 2	ips-SG 220 / 2	ips-SG 320 / 2	ips-SG 420 / 2
Draw-in and cutting width (mm)	120	220	320	420
Drive	Three-phase motor with belt drive			
Power (kW)	3 – 15	5 – 22	7.5 – 30	11 – 30
Draw-in speed range (m/min) <i>with a pellet length of 3 mm</i>	20 – 120	20 – 120	20 – 120	20 – 120
Max. number of strands <i>with a strand diameter of 3 mm</i>	30	55	80	105
Other	Standard pellet length: 3 mm or from 1.0 – 5.0 mm in steps of 5 mm or infinitely adjustable online pellet length setting			

Throughput data

Size	ips-SG 120 / 2	ips-SG 220 / 2	ips-SG 320 / 2	ips-SG 420 / 2
PE, PP (kg/h)	1,050	1,900	2,800	3,650
GPPS, SAN (kg/h)	1,200	2,000	3,200	4,200
ABS, HIPS (kg/h)	1,200	2,000	3,200	4,200
PMMA (kg/h)	1,300	2,400	3,500	4,600
PC (kg/h)	1,350	2,500	2,650	4,800
PET, PBT (kg/h)	1,500	2,750	4,000	5,250
PA 6, PA 6.6 (kg/h)	1,300	2,400	3,520	4,600
PA 6.6, PET, PBT + 10 - 50 % glass fibre (kg/h)	1,500	2,750	4,000	5,250
Thermoplastic elastomers (kg/h)	1,250	2,300	3,350	4,400
Masterbatch on the basis of engineering polymers from 40% fill level (kg/h)	1,500	2,750	4,000	5,250

*Throughput data depends on:
pellet length, pellet diameter, draw-in speed, number of strands, power, cooling time before cut, etc.*

Dimensions

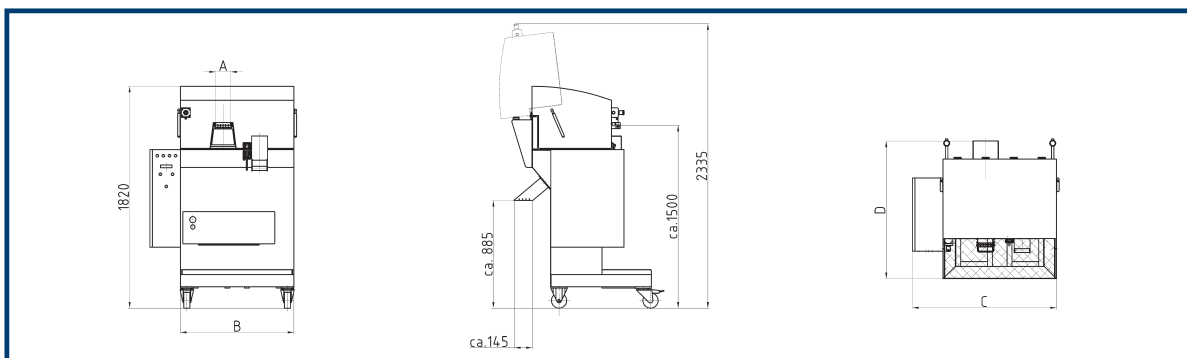

Size	ips-SG 120 / 2	ips-SG 220 / 2	ips-SG 320 / 2	ips-SG 420 / 2
A (mm) approx.	120	220	320	420
Width B (mm) approx.	930	930	1,200	1,200
Width C (mm) approx.	1,180	1,180	1,450	1,450
Length D (mm) approx.	1,130	1,130	1,280	1,280
Height (mm) approx.	1,820	1,820	1,820	1,820
Height of stand intake (mm) approx.	1,500	1,500	1,500	1,500
Height of pellet outlet (mm) approx.	885	885	885	885
Dimension of pellet outlet (mm) approx.	145 x 200	145 x 300	145 x 400	145 x 500
Weight (kg) approx.	700	800	900	1,000

We reserve the right to make changes without notice. The illustrations may include options and accessories that are not part of the standard scope of supply.

