

Strand dewatering unit

ips-SA



- Moveable – capable of universal use, with efficient noise-insulated housing
- Space-saving, compact design
- High air speeds mean high level of efficiency
- Reliable water separation
- Effective removal of the water by pump
- A strand guide roller before and after the suction box
- Easily replaceable split sieve
- Tool-free access to the process water separation unit for maintenance
- Wide height and tilt adjustment range of the suction box
- Flexible options for mounting the suction box, in four different positions on the noise-insulated housing
- Different sizes with dewatering widths of up to 1,000 mm available

Option: Can be adjusted to customers' requirements at any time

Option: Wear protection (split sieve and strand guide rollers)

Option: DUO version with ultra powerful performance for the simultaneous operation of 2 suction boxes

Option: Additional noise insulation to the suction box

Option: Differential pressure measurement to display the filter change status

Technical data

Size	ips-SA 150	ips-SA 250	ips-SA 350	ips-SA 450	ips-SA 550	ips-SA 650	ips-SA 750
Dewatering width (mm)	150	250	350	450	550	650	750
Dewatering length (mm)	80	80	80	80	80	80	80
Strand dewatering – fan data							
Motor power (kW)	2.2	4.0	5.5	7.5	11	15	18.5
Volume throughput (m ³ /min.) approx.	43	52	56	62	73	80	90
Pressure increase (daPa) approx.	390	590	750	870	930	1,000	1,300
Power Dewatering pump (kW)	0.55	0.55	0.55	0.55	0.55	0.55	0.55
Other	All sizes have strand guide rollers before and after the suction box						

Other sizes and designs available on request

Dimensions

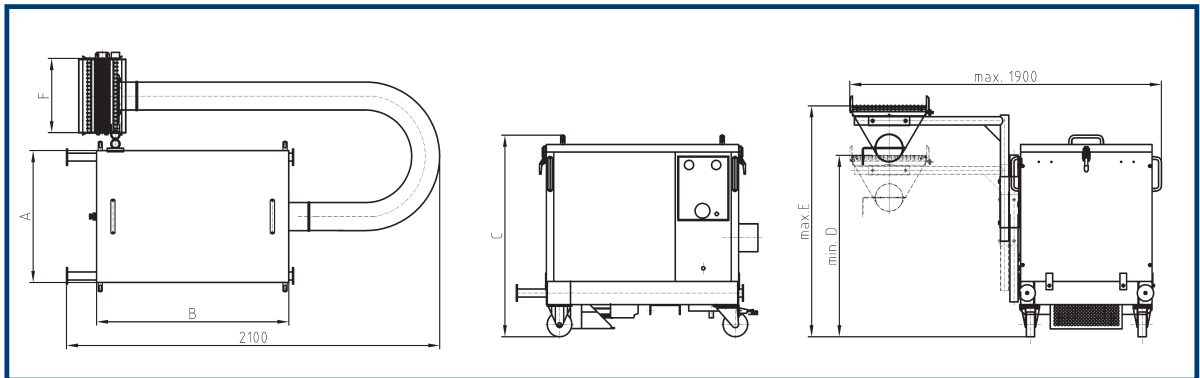

Size	ips-SA 150	ips-SA 250	ips-SA 350	ips-SA 450	ips-SA 550	ips-SA 650	ips-SA 750
Width A (mm) approx.	800	800	800	800	800	930	930
Length B (mm) approx.	1,170	1,170	1,170	1,170	1,170	1,600	1,600
Height C (mm) approx.	1,230	1,230	1,230	1,230	1,230	1,295	1,295
Min. height of strand dewatering box	800	800	800	800	800	800	800
Max. height of strand dewatering box	1,100	1,100	1,100	1,100	1,100	1,100	1,100
F (mm) approx.	150	250	350	450	550	650	750
Weight (kg) approx.	285	300	310	330	350	370	390



Option: Special suction box combined with strand guide



Option: Additional sound insulation to the suction box



Option: Differential pressure measurement to display the filter change status

We reserve the right to make changes without notice. The illustrations may include options and accessories that are not part of the standard scope of supply.

